



ROPER PUMP CO. TECHNICAL MANUAL

TM:001

Revised
12/15/03

Subject: Mounting Pumps

By: Laney Seabolt

Introduction

Pumps must be mounted properly in order to operate at their full design capability and meet their life expectancy. Mountings must be rigid with proper alignment maintained between the pump shaft and the driver shaft. Piping forces must also be controlled. Improper mounting of the pump can lead to premature seal failure and reduction of bearing life. This document covers many types of mountings, pump sizes and pump types.

Safety

Drive line protection is a major factor when mounting a pump and related equipment. Become familiar with and follow all safety related requirements of OSHA and all other applicable safety regulations set forth by federal, state, and local government.

! WARNING



- Operating without guards could result in serious injury or death.
- Machinery in operation can grab, crush, cut, mangle and dismember.
- Do not operate without adequate guards in place.

Preparation of Foundation

Locate the pump so that it is as low and as close to the fluid source as practical and so that piping to and from the pump will be as short and simple as practical. The pump and its driver must be accessible for inspection and maintenance. Accessibility to the unit and adequate clearance should be a major thought in any installation. The driver must be suitable for the environment (for example: open, splash proof, totally enclosed, or explosion proof electric motor). If the driver is not suitable, choose a different location or obtain another driver.



ROPER PUMP CO. TECHNICAL MANUAL

TM:001

Revised
12/15/03

Subject: Mounting Pumps

By: Laney Seabolt

For best pump-driver unit life, mount each unit on a strong, fabricated, structural steel baseplate with a proper foundation. A good foundation is of major importance to the total installation. A thick, heavy concrete foundation is best since it is heavy enough to support the baseplate rigidly and absorb strain and shock. *Do not bolt the pump feet directly to a concrete base. The foot area of the pump is too small to distribute the load properly on concrete. Doing so may result in failure of the concrete and a loss of tension on the mounting bolts.* Locate anchor bolts for the baseplate in the foundation. Use a pipe sleeve, two to three times as large as the anchor bolts, around the anchor bolts to allow some lateral bolt movement during final positioning of the unit.

Place the unit, with the pump and driver mounted on the baseplate, on the foundation and disconnect the coupling (flexible coupling, belts and sheaves, etc.). DO NOT reconnect the coupling until all alignment operations are complete. Support the baseplate on rectangular metal blocks and shims or on metal wedges having a small taper. Place the support pieces close to the anchor bolts and directly under the part of the baseplate carrying the greatest weight. Space the support pieces close enough to give uniform support. Allow a gap of about $\frac{3}{4}$ inch [19mm] to 1-1/2 inches [38 mm] between the foundation and baseplate for grouting. Refer to Fig. 1.

Adjust the metal supports or wedges until the shafts of the pump and driver are level. At this time, check the faces of the inlet and discharge connections of the pump of horizontal or vertical position using a level. Correct the positions, if necessary, by adjusting the supports or wedges under the baseplate as required.

For maximum rigidity and lower noise levels, grout the baseplate to the foundation. Use a good grade of nonshrink grout. When all alignments are correct (refer to the section on Aligning Pump and Driver), tighten the anchor bolts evenly but not too firmly. Then grout the unit to the foundation. Completely fill the baseplate with grout. It is desirable to grout the leveling pieces, shims, or wedges in place. Fill the spaces between the anchor bolts and sleeves with grout, also.

Allow the grout to dry according to the manufacturer's instructions. DO NOT fully tighten the anchor bolts until the grout has hardened.



ROPER PUMP CO. TECHNICAL MANUAL

TM:001

Revised
12/15/03

Subject: Mounting Pumps

By: Laney Seabolt

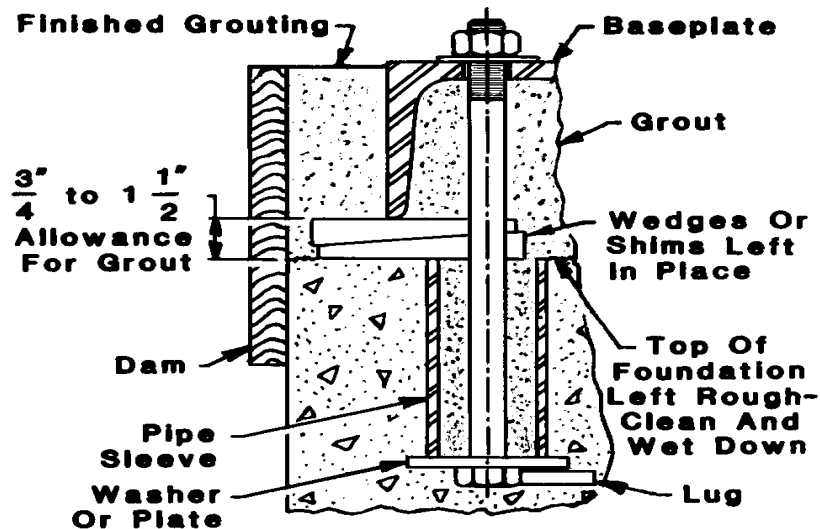

Figure 1: Typical Baseplate Anchoring

After the grout has hardened and the anchor bolts have been properly tightened, check the unit for parallel and angular misalignment, and if necessary, take corrective measures. After the piping to the unit has been connected, check the alignment again.

NOTE: Attempts to correct alignment in one direction may alter the alignment in the other direction. Therefore, it is necessary to check alignment in all directions after making any adjustments.

Schedule semiannual inspections and checks of the foundation anchor bolts as part of a preventive maintenance program. If loose foundation bolts are found, tighten them and check the unit alignment.

Normal mounting for this pump is horizontal with the pump above the baseplate, properly grouted to a concrete foundation placed in or on solid earth. Mountings other than described above (such as vertical mounting, wall mounting, ceiling mounting, etc.) may require special components and precautions. Extra pump supports, special drivers, and extra anchor bolts may be necessary in unusual mountings. If your application requires other than normal mounting, as described above, you are urged to consult Roper Pump Company for assistance in determining any special needs that may be required.

Truck Mounting



ROPER PUMP CO. TECHNICAL MANUAL

TM:001

Revised
12/15/03

Subject: Mounting Pumps

By: Laney Seabolt

The mounting pads for truck mounted pumps must be rigid and properly aligned with the driver. When PTO drives are used, always check with the manufacturer of the PTO equipment to determine the alignment required for proper operation of the PTO and the type of guarding that must be used. See the section on Aligning Driver and Pump.

The 3600 Series, "Z" Series, "T" Series and Sanitary Truck Pumps are the pumps that are commonly mounted on Trucks. These pumps were designed to be mounted by their feet with the exception of the 3622SBF pumps. These pumps may be mounted with the feet in the three, nine and twelve o'clock position as well as the standard six o'clock position. DO NOT use these pumps with a port type mount as is used with a 3622SBF pump.

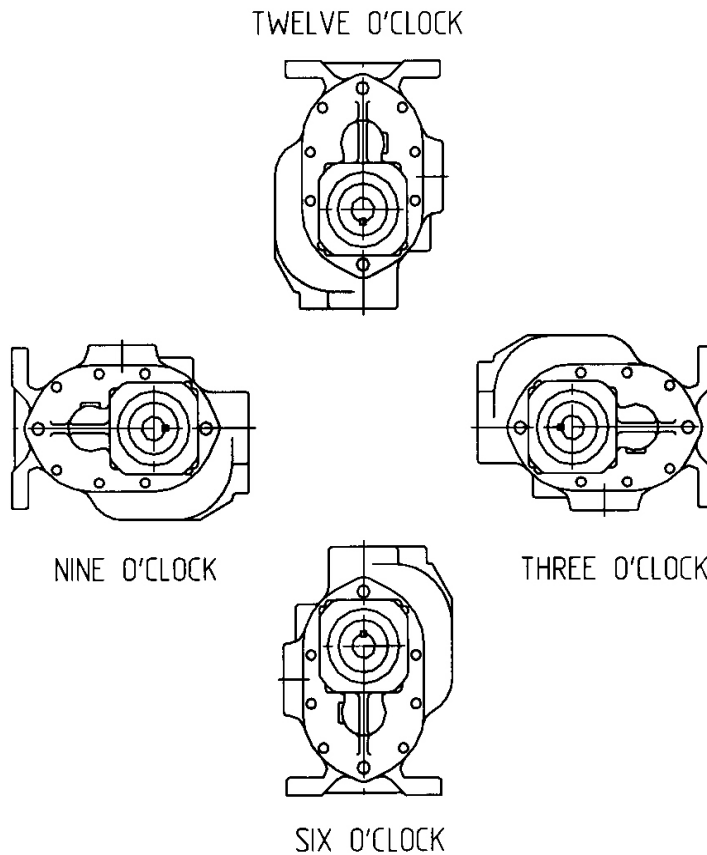

Mounting Positions



The 3622 SBF pump is designed to be suspended by the top port. DO NOT suspend a 3622SBF by the side port.

The suspended truck mount assembly for the 3622 SBF is designed to be bolted to the truck frame rails. The pump is then mounted to the pipe flange by the top port.

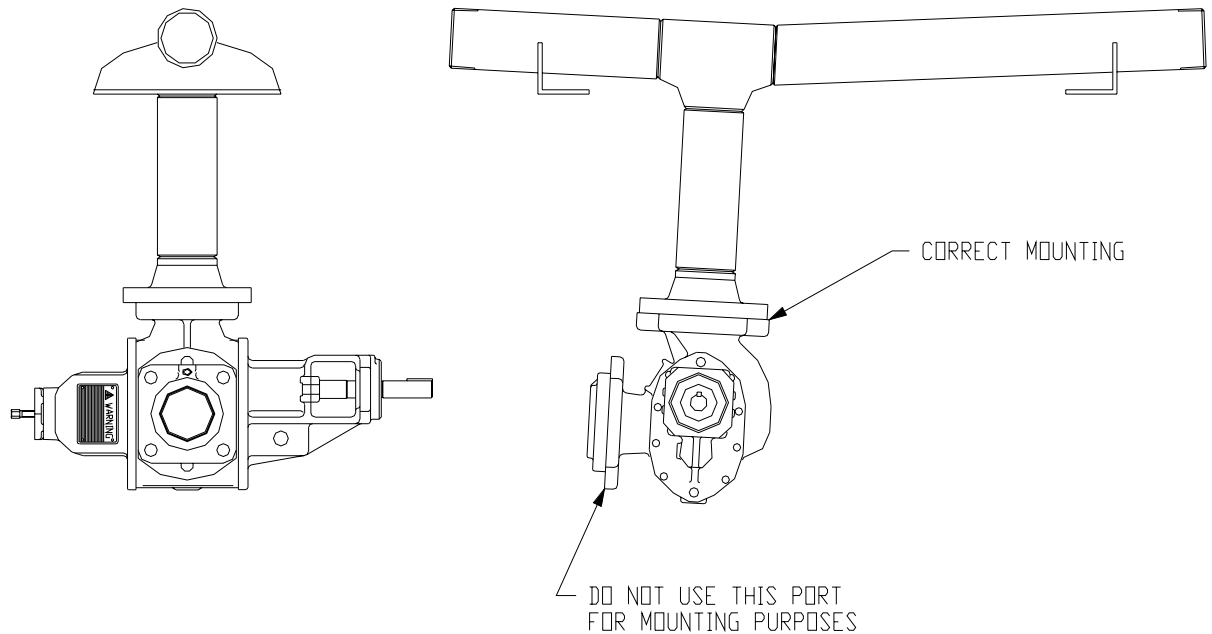

3622 SBFRV Type 3 Suspended Truck Mount

Aligning Driver and Pump

The flexible coupling or belts and sheaves must be accurately realigned during and after installation. Refer to the flexible coupling or belt and sheave manufacturer's recommendations and instructions for the requirements for proper alignment. Also refer to the section on Preparation of Foundation, for additional information.

Flexible Coupling

DO NOT use a flexible coupling to compensate for misalignment of the driver and pump shafts. The purpose of the flexible coupling is to compensate for temperature changes and to permit end movement of the shafts without interference with each other while transmitting power from the drive to the pump.

The faces of the coupling halves should be spaced far enough apart so that they cannot strike each other when the driver rotor is moved hard over toward the pump. The necessary tools for



approximate checking of the alignment of a flexible coupling are a straight edge and a taper gauge or a set of feeler gauges.

	<p>Make sure there is no chance of the driver becoming energized while aligning driver and pump. Getting caught in rotating parts of the drive system will cause serious personal injury or death. DO NOT start or operate pump without guards in place.</p>
---	---

There are two forms of misalignment between the driver shaft and the pump shaft. The first is angular misalignment, where the axes of the shafts are concentric but not parallel. The other is parallel misalignment, where the axis of the shafts are parallel but not concentric. Refer to Fig. 2.

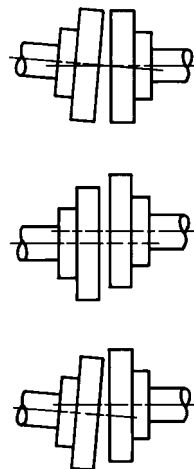

Fig. 2: Misalignments: Top, Angular; Center, Parallel; Bottom, Both

Make the check for angular alignment by inserting the taper gauge or feeler gauges between the coupling faces and comparing the distance between the faces at four points spaced at 90° intervals around the coupling. The unit will be in angular alignment when the measurements show that the coupling faces are the same distance apart at all points.

Make the check for parallel alignment by placing a straight edge across both coupling halves at the top, bottom, and at both sides. The unit will be in parallel alignment when the straight edge



ROPER PUMP CO. TECHNICAL MANUAL

TM:001

Revised
12/15/03

Subject: Mounting Pumps

By: Laney Seabolt

rests evenly on the coupling halves at all positions. Allowance may be necessary for temperature changes and for coupling halves that do not have the same outside diameter. Take care to have the straight edge parallel to the axes of the shafts.

Correct angular and parallel misalignment by placing shims under the mounting feet of the equipment. After each change, it is necessary to recheck the alignment already made in another direction.

Belts and Sheaves

Some applications involving low discharge pressure and slow speeds may permit the mounting of the driven sheave directly on the pump shaft. However, it is recommended that all belt drive assemblies be designed with a separate jackshaft mounted on pillow blocks to carry the side loads of the sheaves and belts and a flexible coupling connecting the jackshaft to the pump shaft.

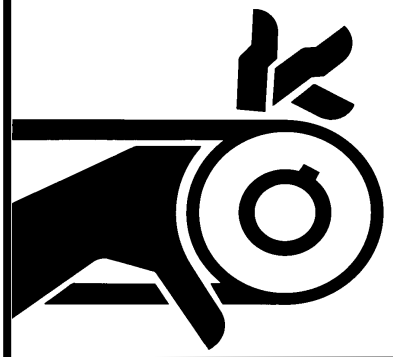
⚠ DANGER	
	<p>Make sure there is no chance of the driver becoming energized while aligning and adjusting the belts. Getting caught in rotating parts of the drive system will cause serious personal injury or death. DO NOT start or operate pump without guards in place.</p>

The driver and pump shafts must be parallel, and the belts at right angles to these shafts. Misalignment will cause undue belt wear, or turn-over in the grooves. *Approximate* alignment should be checked by placing a long straight edge evenly across the rims of both sheaves. If the faces of the sheaves are not of equal width, the alignment may be checked by resting the straight edge across the rim of the widest sheave and measuring the distance from the straight edge to the nearest belt groove with a scale. Adjust either sheave on the shaft to equalize these dimensions.

The driver should be mounted with adequate provision for belt center distance adjustment. Provide a minus adjustment to permit belt installation without stretching and a plus allowance to provide belt take-up.

DO NOT pry, twist, or force the belts over the sheave grooves. This will damage the belts and greatly reduce the belt life. Shorten the drive by moving the driver enough to permit fitting the belts in the proper grooves. When the belts are in place, increase the center distance until proper



ROPER PUMP CO. TECHNICAL MANUAL

TM:001

Revised
12/15/03

Subject: Mounting Pumps

By: Laney Seabolt

belt tension is obtained. Adjust take-up until only a slight bow appears on the slack side of the drive when it is operating. All the belts must be pulling evenly. Belt tension should be reasonable. It is not necessary to have belts excessively tight.

During the first few days of operation, the belts will seat themselves in the sheave grooves. After that, the drive must be adjusted to take up the slack. Slipping belts will result in lowered capacity. Squealing or smoking belts are sometimes a clue to the slipping of belts.

Keep belts clean and free from oil. Stop drive to clean belts. DO NOT attempt to clean belts while the drive is operating. Clean oily belts with a cloth dampened with soap and water. Never install new belts on the same drive with used belts. DO NOT use sheaves with chipped or worn grooves. For hazardous locations, check to see if an antistatic belt should be used. When purchasing replacement belts, the same size and type should be ordered as furnished originally.

Power Take-Off Drive Systems

When mounting a pump on a vehicle with a PTO drive, always check with the manufacturer of the PTO equipment to determine the alignment required for proper operation of the PTO. The mount for the pump must be rigid. The pump must be mounted the way it was designed to be mounted. 3622 SBF pumps must be mounted by the top flange only. DO NOT use the pump side port to mount a 3622 SBF pump. Pumps with feet must be mounted by the feet. DO NOT use the pump ports to mount a pump that has feet. It is acceptable to mount a foot mounted pump in the three, nine, or twelve o'clock position as well as the standard six o'clock position as long as proper shaft alignment is maintained.

! DANGER	<p>Make sure there is no chance of the driver becoming energized while aligning the power take-off shafting. Getting caught in a power take-off drive system will cause serious injury or death. Proper guarding must be provided for all power take-off drive systems.</p>
	

Serious injuries and deaths have resulted from persons becoming caught in power take-off (PTO) drive systems. Loose or dangling clothing and slippery or unsure footing are factors in many PTO accidents. DO NOT work on or adjust a pump driven by a PTO drive system while it is in



ROPER PUMP CO. TECHNICAL MANUAL

TM:001

Revised
12/15/03

Subject: Mounting Pumps

By: Laney Seabolt

operation or has a chance of the driver becoming energized except as specified in the Installation and Operation Manual for specific pumps in regard to procedures for setting relief valves.

Unless properly designed, guarded, and maintained, all drive systems are dangerous.

Guarding PTO Drive Shafts

PTO drive systems can be dangerous and when used, additional safety precautions, including guarding, may be required and must be provided by the drive system installer. Roper Pump Company has no responsibility for recommending or providing proper guarding or other safety measures in any particular application.

The installation of proper guards for the power take-off and its associated equipment is the responsibility of the drive system designer and the installer who know the particular product application and the user's exposure to danger. *The ultimate responsibility for the safe application and installation is the user's.*

Installation of Pipes

- DO NOT connect raised face flanges to the ports of a cast iron pump.
- DO use flat faced flanges with cast iron pumps.

Piping must be installed and checked carefully. Allow for any expansion or contraction.

Any external force or moment (torque or twist) applied on the pump ports by the piping will cause stresses in the pump and its foundation. This may cause misalignment that could result in hot bearings, worn couplings, or excessive vibration. Such forces or moments may be caused by improperly aligned piping or by thermal expansion of the piping when pumping hot or cold fluids. The piping should be supported independently. Use flexible piping connectors and insure that they are properly anchored.

If an expansion joint is installed in the piping between the pump and that nearest point of anchor in the piping, a force equal to the area of the expansion joint (which may be considerably larger than the normal pipe size) times the pressure in the pipe will be transmitted directly to the pump.

Pipe couplings that do not provide an axially rigid connection have the same effect. This reaction force can be so large that it would be impractical to design suitable components to withstand the force. If an expansion joint or nonrigid coupling is used, install a pipe anchor between it and the pump. If properly installed, this will eliminate the forces mentioned above.

The pump port size does not necessarily establish the correct pipe size. Piping must be sized and arranged to provide ample inlet pressure at the pump and to insure that the discharge pressure will be at least as low as the rated pressure of the pump. If the fluid to be pumped is viscous, or the piping long, or the suction lift or static discharge head somewhat high, piping one or two



ROPER PUMP CO. TECHNICAL MANUAL

TM:001

Revised
12/15/03

Subject: Mounting Pumps

By: Laney Seabolt

sizes larger may be required. Friction losses should be carefully calculated (see Hydraulic Institute Engineering Data Book or similar authority for friction loss data) and compared to the pump ratings before the installation is made. Where valves are used in the piping system, gate, ball, or butterfly valves are preferable to globe or angle valves. 90° long radius or 45° elbows are preferable to standard short radius elbows. NEVER place a valve between the pump and system relief valve.

Threaded Port Connections

American National Standard Taper Pipe Threads (NPT) are standard for pipe plugs and threaded ports of the pump. British Standard Pipe Threads (BSP) are available upon request for most pump sizes.

To produce a pressure tight joint, a thread sealant must be used. TFE tape is generally not recommended where cast iron is used as one or more parts of the joint. The use of TFE tape for installing cast iron fittings may cause damage to the pump or fittings.

The following is a partial list of sealants that may be used when making up joints on the pump:

- PST Pipe Sealant No. 567 – Loctite Corp.
- Rectorseal No. 5 – The Rectorseal Corp.
- Leak Lock – Highside Chemical, Inc.

Follow the sealant manufacturer's instructions when making up a joint.